

Exercise 3.3 (Figure 3.21)

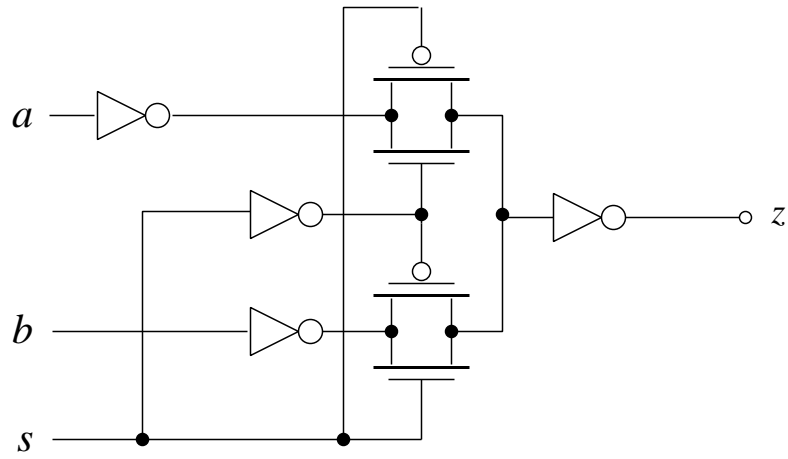

Exercise 3.5 (Figure 3.22)

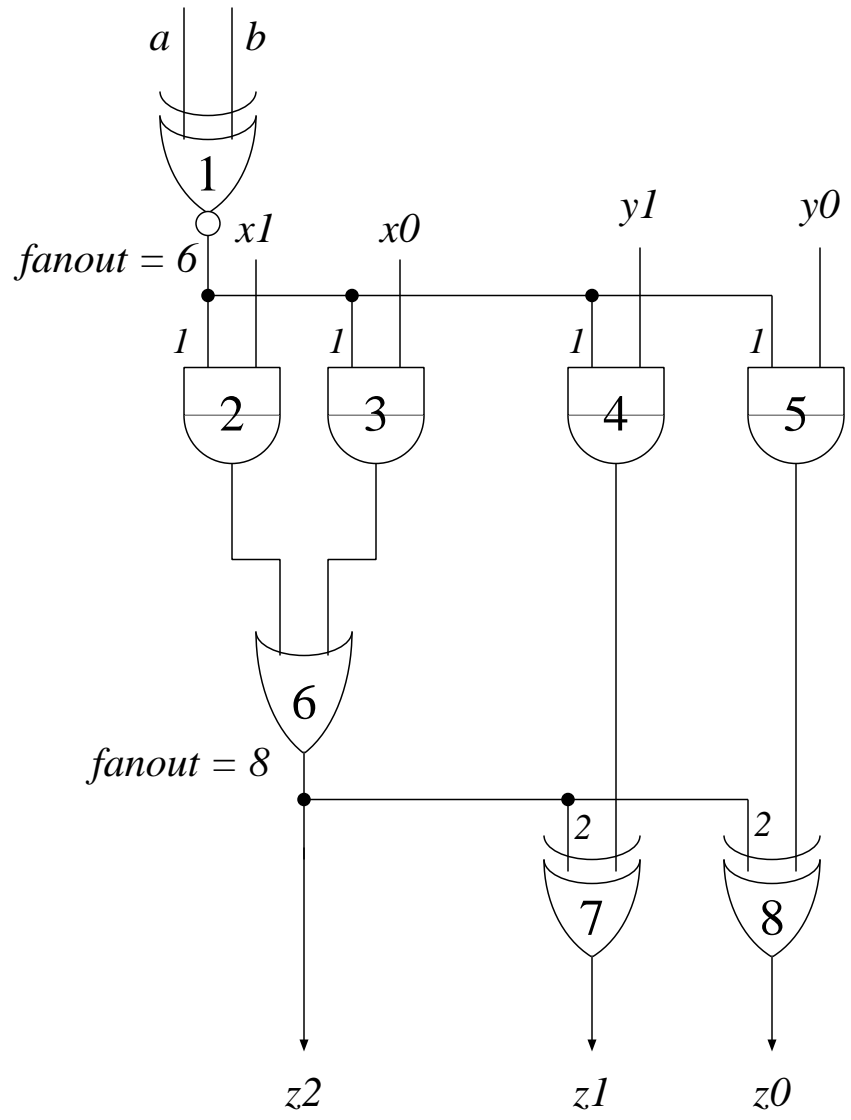

Exercise 3.6 (Figure 3.23)

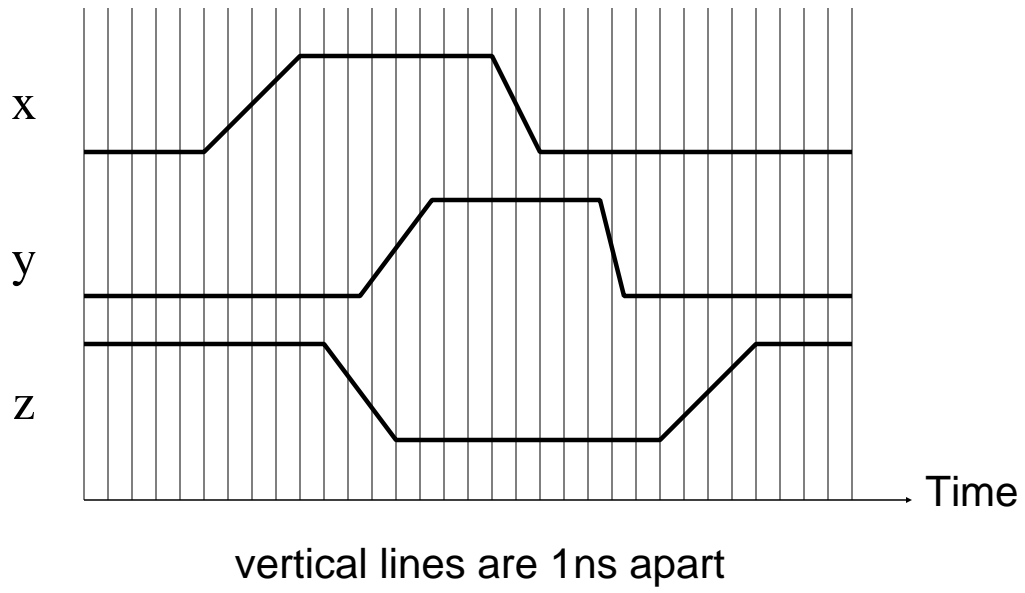

Exercise 3.7.(Figure 3.24)

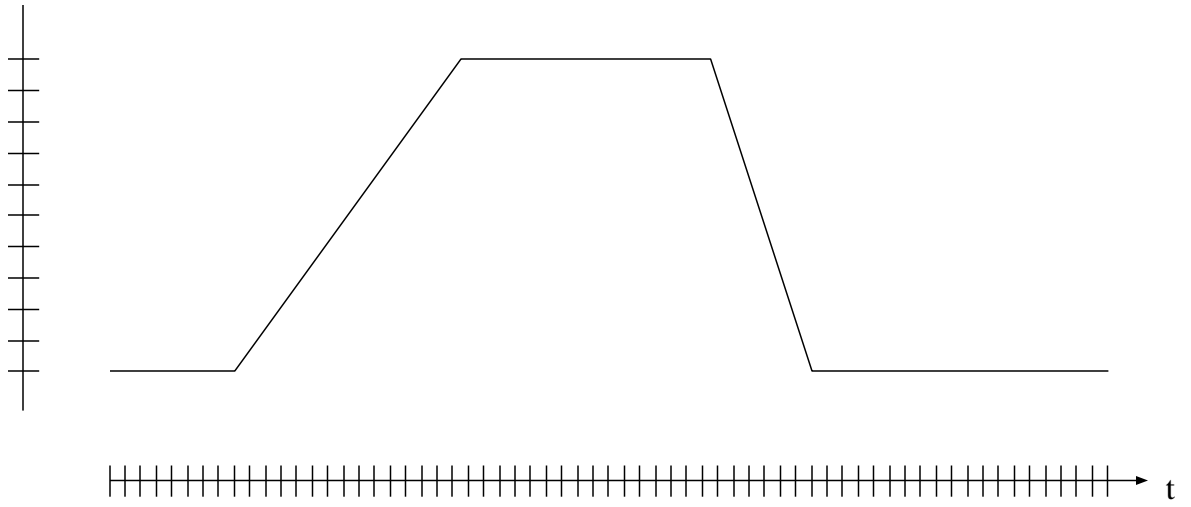

each tick: 0.25ns

Exercise 3.10 (Figure 3.25)