

Exercise 8.1 (Figure 8.3)

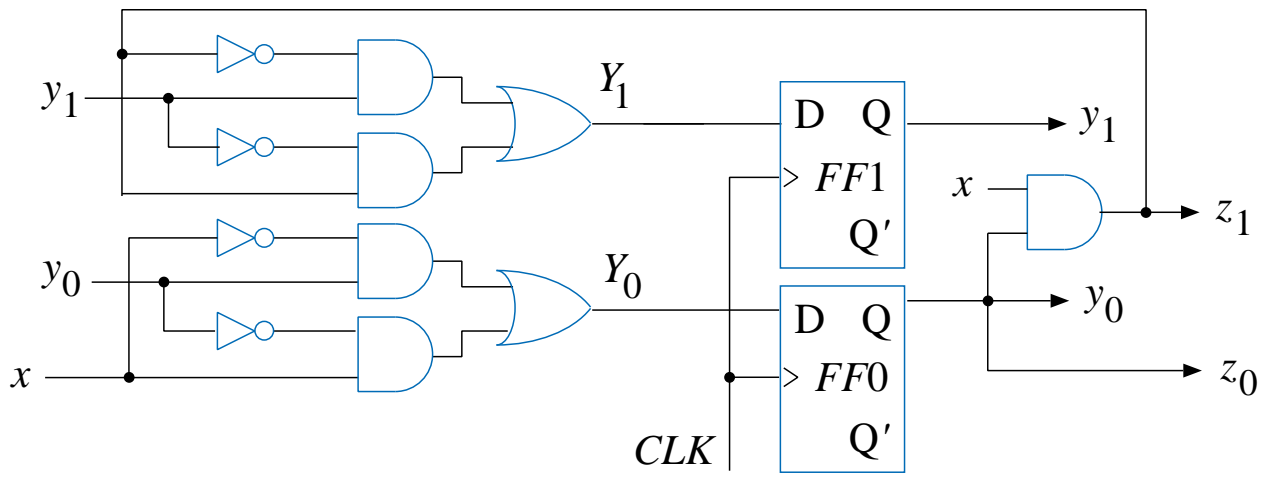

$t_p = 0.5 \text{ ns}$ for gates $t_{su} = 1.0 \text{ ns}$ for cells $t_h = 0.5 \text{ ns}$ for cells
 $t_p = 3.0 \text{ ns}$ for cells

Exercise 8.2 (Figure 8.38)

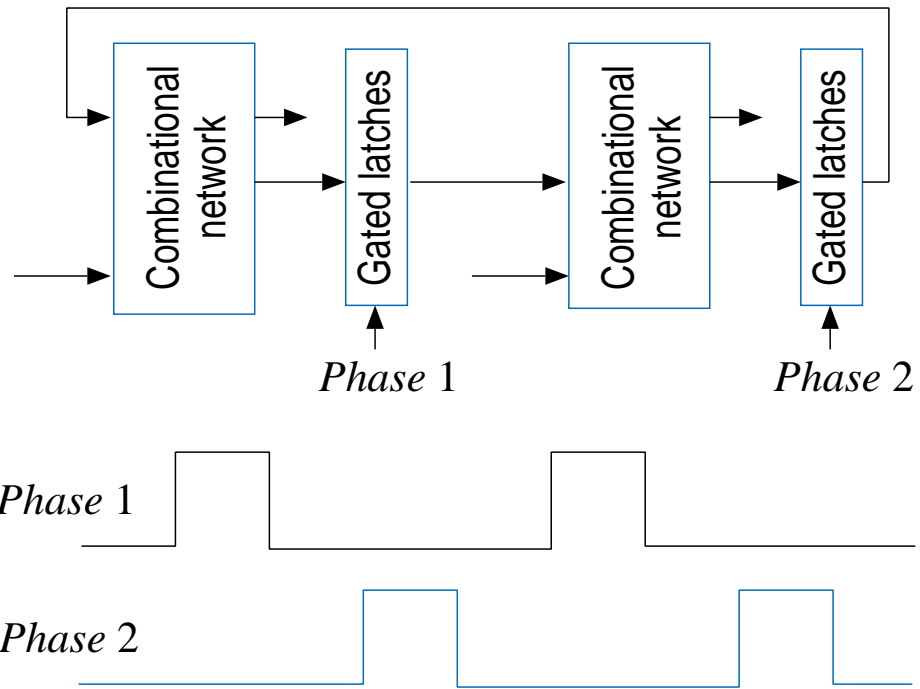

Exercise 8.3 (Figure 8.39)

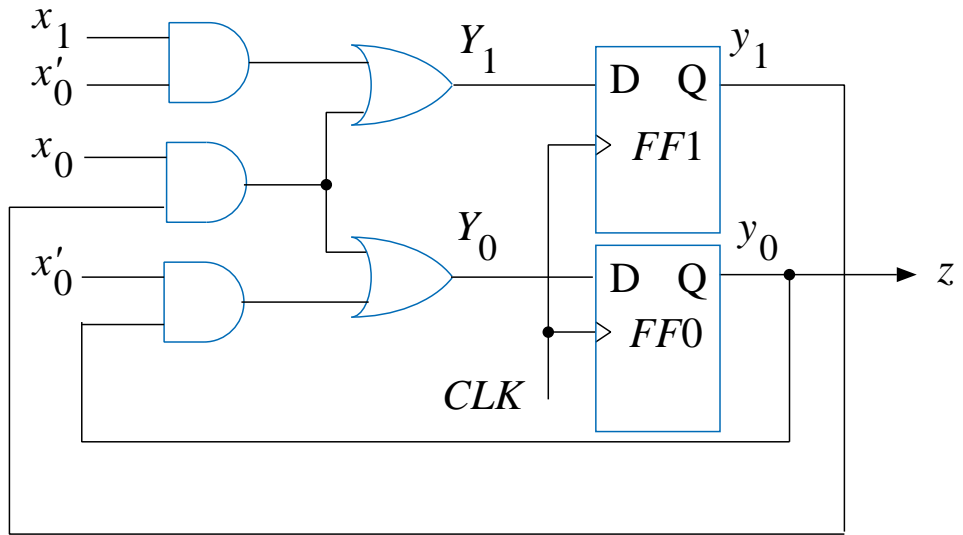

Exercise 8.4 (Figure 8.40)

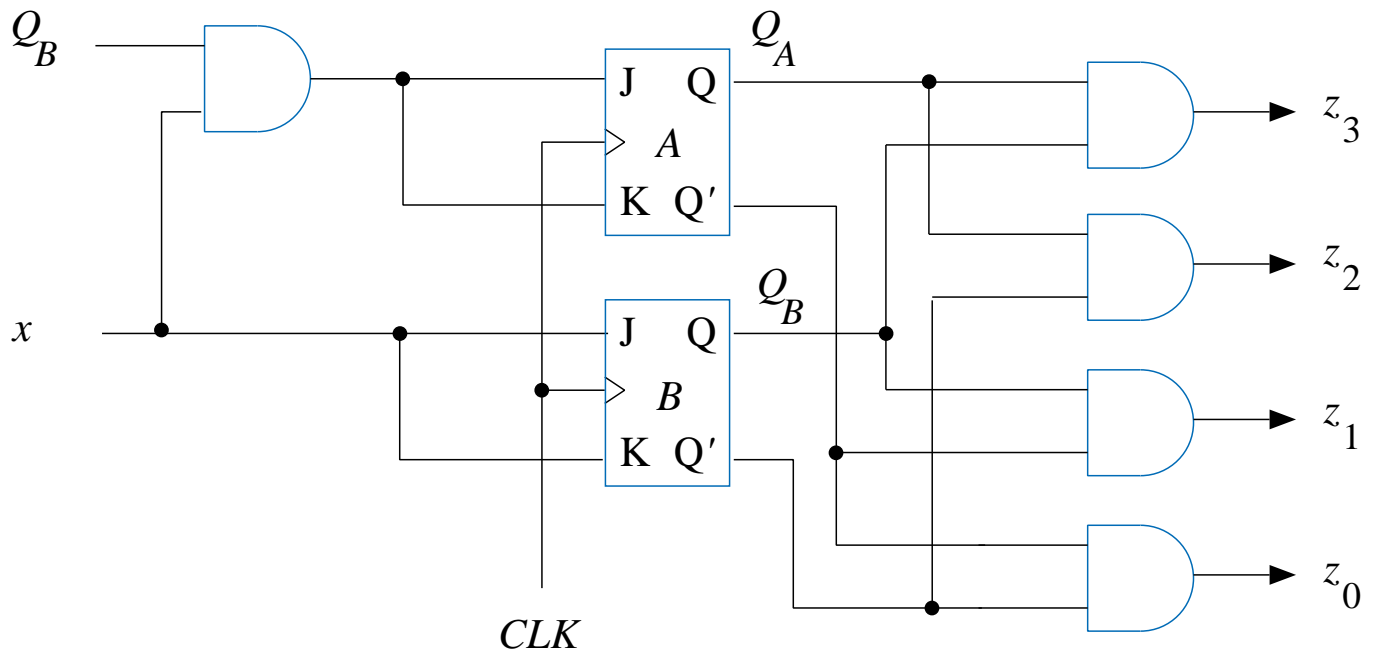

Exercise 8.16 (Figure 8.40)

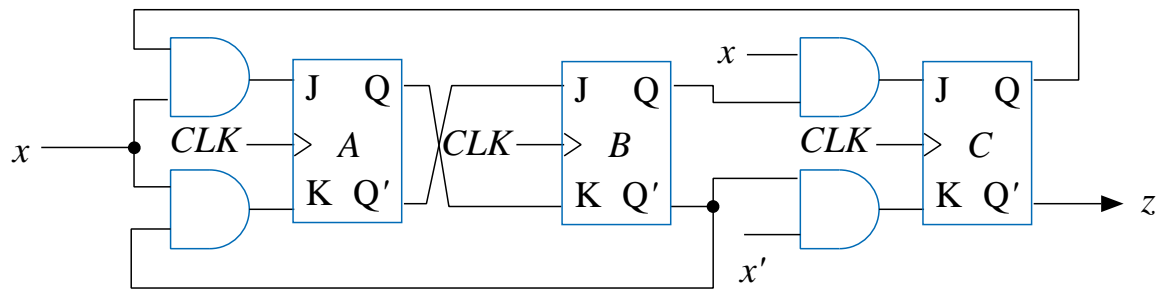

Exercise 8.17 (Figure 8.42)

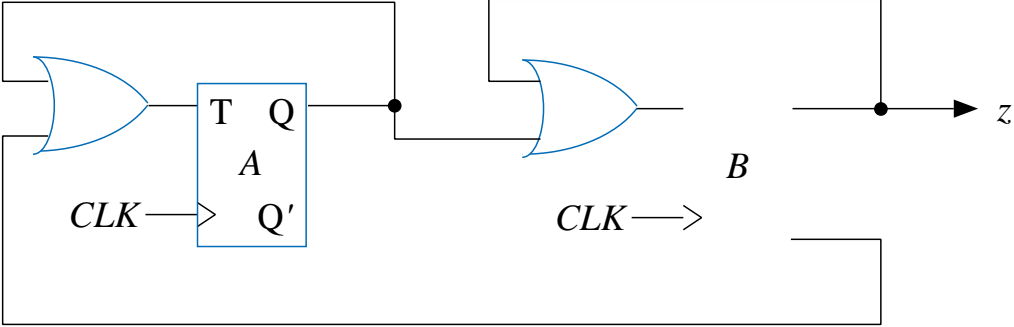

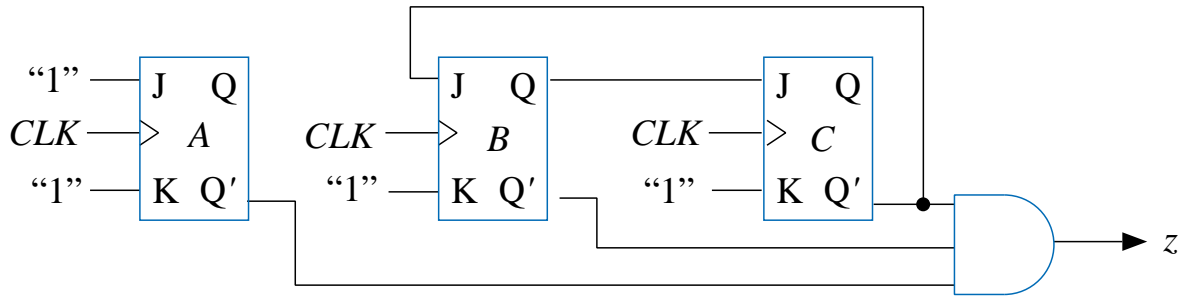

Exercise 8.19 (Figure 8.44)

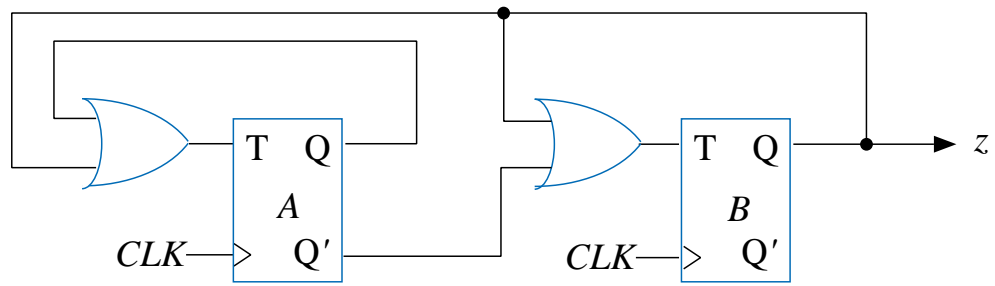

Exercise 8.20 (Figure 8.45)

